

# NovoSwing

Operator for hinged gates with maximum leaf width of 1,80 m

- ✓ electro-mechanical hinged gate operator 24 V
- ✓ suitable for hinged gates with maxi. 1,80 m leaf width
- ✓ integrated force observation with obstacle detection
- ✓ soft start and soft stop adjustable
- ✓ quick and easy 3-button programming
- ✓ electronic running way detection (without limit switch)
- ✓ certified by standards and TÜV approved



### Scope of delivery NovoSwing set:

- 2 pieces NovoSwing operator
- Control unit NovoSwing
- Radio receiver 433 MHz
- Hand transmitter MAX 43-2

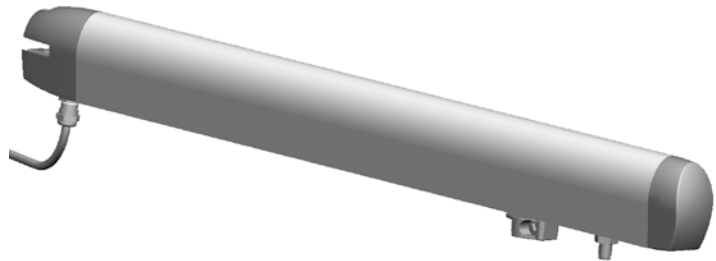

### Opening angle NovoSwing operator

A in mm	B in mm					
	100	110	120	130	140	150
100	85°	85°	86°	86°	87°	87°
110	91°	91°	91°	91°	91°	91°
120	96°	96°	95°	95°	95°	95°
130	101°	100°	99°	99°	98°	98°
140	106°	105°	104°	103°	102°	101°
150	109°	108°	107°	106°	105°	105°
160	113°	112°	111°	109°	109°	108°

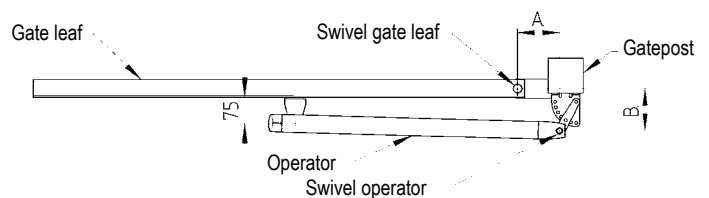

The illustration above and the chart beneath show the opening angles, which are practicable during the installation of the NovoSwing operator.

### Installation situation NovoSwing operator

The illustration represents a possible installation situation of the NovoSwing operator in combination with a hinged gate. Additionally shown are light barriers, sockets, a key contact, a bar antenna, an emergency touch contact and a warning lamp. The related Novaferm tomatic articles with order number can be found on page 8 or in chapter „accessories gate systems“ listed as Z3.

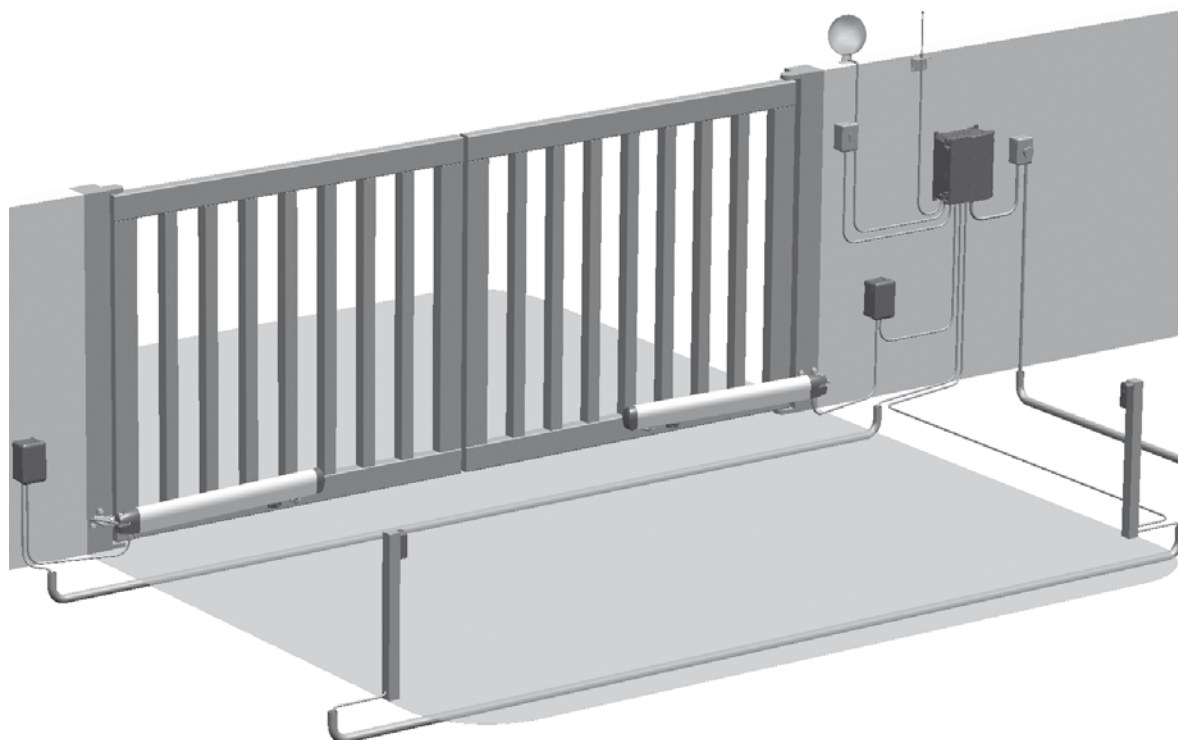

### Technical data NovoSwing operator

Maximum weight of gate	200 kg
Maximum leaf width	1,8 m
Minimum leaf width	0,8 m
Maximum height of gate	2,0 m
Leaf surface	min 50% wind penetrable
Connection voltage	230 V +10% 50Hz
Power consumption	250 W
Operation temperature	-20 °C / +60 °C
Shear force	1500 N
Pull force	1500 N
Opening and closing cycle	19 s
HUB	350 mm
ED	30%
Soft start / stop	adjustable

## Connection diagram and dimensions NovoSwing control unit

1. External antenna
2. Connection start
3. Stop A (stops in both directions)
4. Stop B (reverses in direction close)
5. Mains supply 24 V AC / 2,0 AT
6. Status relay Gate Open
7. Status relay Gate Close
8. Motor 1 – active leaf
9. Incremental encoder motor 1
10. Motor 2 – inactive leaf
11. Incremental encoder motor 2
12. EI Taco for electric lock or lighting
13. Warning lamp 230 V
14. Mains supply 230 V / 50 Hz
15. Radio receiver module UHF 433 MHz
16. 7-segment display for programming
17. 3-button programming buttons

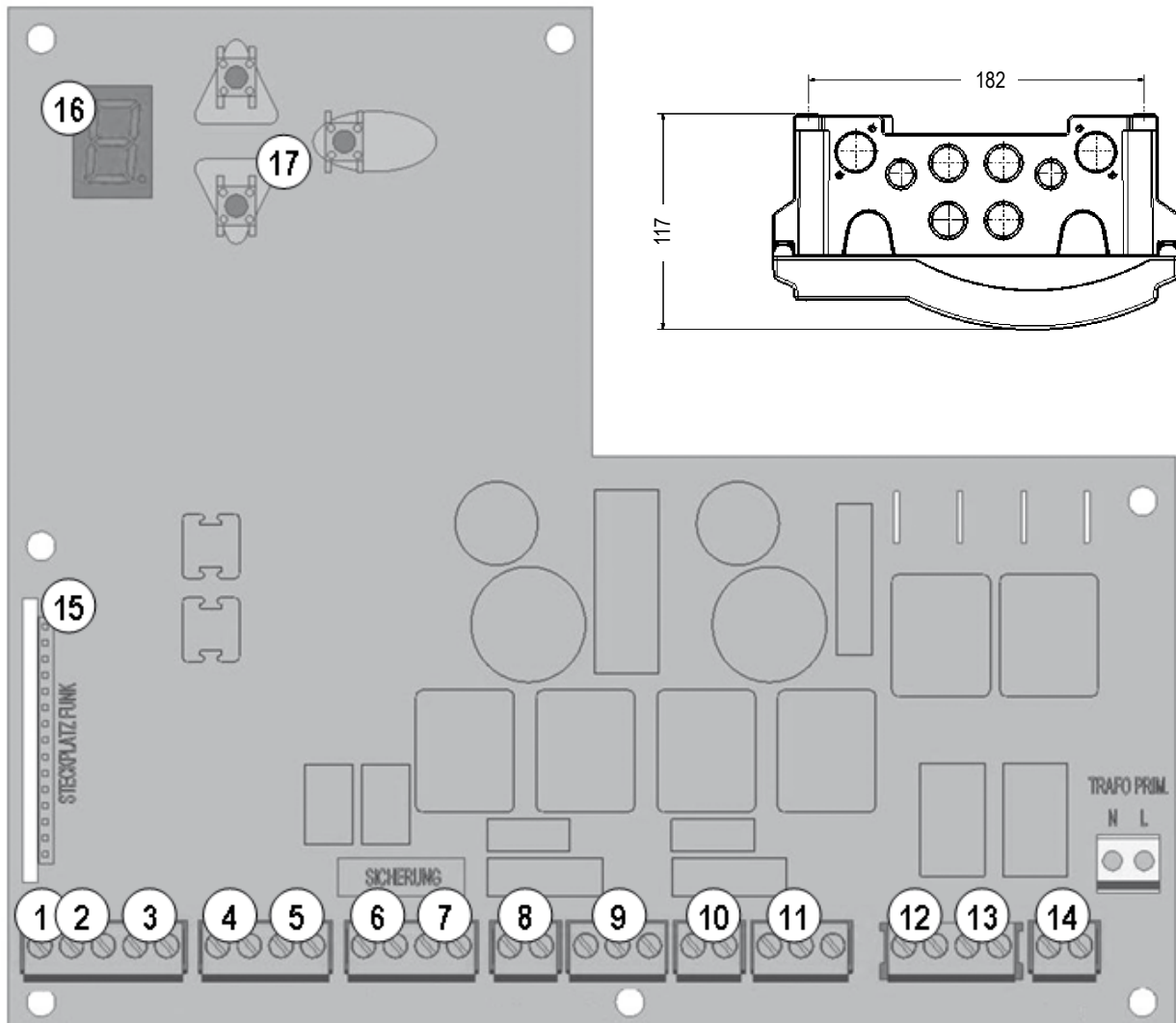
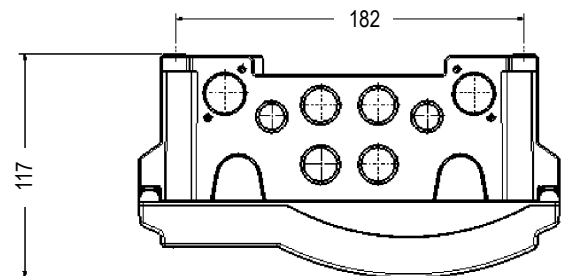
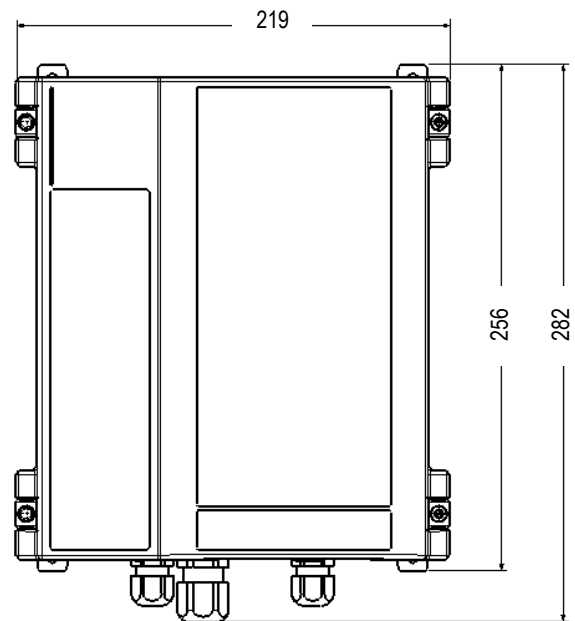

Dimensions NovoSwing operator

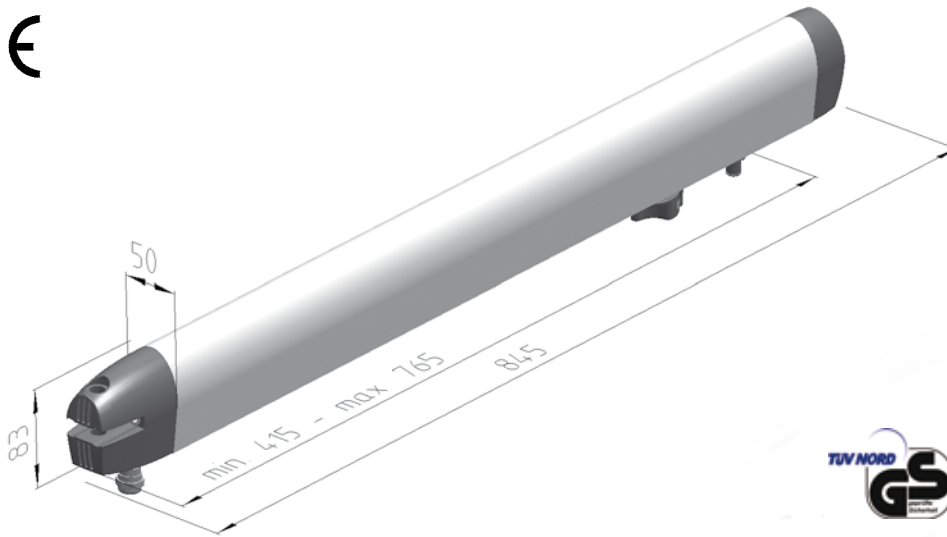

Description:	Article Number:	
<i>NovoSwing Set</i>	155000-01-1-50	1 piece

Recommended standard accessories

Description:	Article Number:
1. Hand transmitter MAX 43-2	020223-31-3-32
2. Hand transmitter MAX 43-4	020226-31-3-32
3. Warning lamp BL 230	020332-31-3-32
4. Light barrier LS 5	020219-31-3-32
5. Key contact KT 3-1 AP	020024-31-3-32
6. Electric lock	020242-31-3-32
7. DigiCode Professional	148700-01-1-50



Of course, the NovoSwing operator is also compatible with further standard accessories. Please view chapter „accessories gate systems“ listed as Z3.